



US005879637A

United States Patent [19]
Titmas

[11] **Patent Number:** **5,879,637**
[45] **Date of Patent:** **Mar. 9, 1999**

- [54] **APPARATUS FOR HYDROLYZING CELLULOSIC MATERIAL**
- [75] Inventor: **James A. Titmas**, Fairlawn, Ohio
- [73] Assignee: **Eau-Viron Incorporated**, Hudson, Ohio
- [21] Appl. No.: **950,896**
- [22] Filed: **Oct. 15, 1997**

Related U.S. Application Data

- [62] Division of Ser. No. 644,401, May 1, 1996, Pat. No. 5,711, 817.
- [51] **Int. Cl.⁶** **B01J 3/04**
- [52] **U.S. Cl.** **422/129; 422/242; 422/184.1; 127/1; 166/300**
- [58] **Field of Search** 127/1, 36, 37, 127/38, 43; 162/78, 81; 435/162, 283.1, 161, 163, 165, 289.1, 293.1, 295.1, 295.2; 422/129, 242, 184.1; 210/741, 757, 761, 766; 166/244.1, 250.01, 300, 302, 303

References Cited

U.S. PATENT DOCUMENTS

| | | | |
|-----------|---------|-------------|---------|
| 3,449,247 | 6/1969 | Bauer | 210/63 |
| 3,464,885 | 9/1969 | Land et al. | 210/17 |
| 3,853,759 | 12/1974 | Titmas | |
| 4,272,383 | 6/1981 | McGraw | 210/741 |
| 4,792,408 | 12/1988 | Titmas | 210/747 |
| 5,135,861 | 8/1992 | Pavilon | 435/162 |
| 5,160,581 | 11/1992 | Titmas | 162/61 |

FOREIGN PATENT DOCUMENTS

| | | | |
|-----------|--------|---------|--------|
| 27 44 067 | 4/1979 | Denmark | 127/37 |
|-----------|--------|---------|--------|

OTHER PUBLICATIONS

"A review of developments in the acid hydrolysis of cellulosic wastes" by Anderson et al. *Proc Instn Mech Engrs* vol. 201 No. C2, pp. 117-123 (1987).

"An Evaluation of Hydrolysis Technology for the Conversion of Cellulosic Feedstocks to Ethanol and Other Chemicals" by Moore-Bulls et al., Presented at Seventh Canadian Bioenergy R&D Seminar, Ottawa, Ontario, 9 pages (Apr. 1989).

"An improved process for converting cellulose to ethanol" by Goldstein et al., *Tappi Journal*, pp. 135-140 (Aug. 1992).
TVA "Biomass Research Program Update" vol. 2, No. 1, 2 pages (Nov. 1989).

TVA "Biomass Research Program Update" vol. 3, No. 1, 2 pages (Oct. 1990).

TVA "Biomass Research Program Update" vol. 4, No. 1, 2 pages (May 1991).

"Comparison of MSW Utilization Technologies—Ethanol Production, RDF Combustion, and Mass Burning" by Bulls et al., Presented at the Southern Biomass Conference, Baton Rouge, Louisiana, pp. cover-12 (Jan. 1991).

"Ethanol Production from Refuse-Derived Waste Using Dilute Sulfuric Acid Hydrolysis" by Barrier et al., National Bioenergy Conference, Coeur d'Alene, Idaho, 10 pages (Mar. 1991).

(List continued on next page.)

Primary Examiner—William H. Beisner
Attorney, Agent, or Firm—Renner, Kenner, Greive, Bobak, Taylor & Weber

[57] **ABSTRACT**

Cellulosic material is converted to ethanol by hydrolyzing the cellulosic material in a gravity pressure vessel (50), and fermenting the product thereof. The gravity pressure vessel (50) employed is adapted to accommodate a continuous hydrolysis reaction and maximize the fermentable product yield on a commercial scale. The gravity pressure vessel (50) employed is also adapted to maximize the thermodynamic efficiencies of the hydrolysis reaction, as well as the entire ethanol producing process.

11 Claims, 6 Drawing Sheets

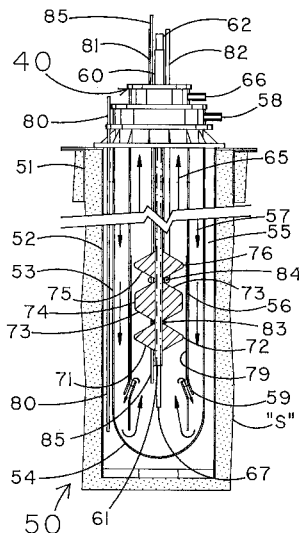

OTHER PUBLICATIONS

“Feedstock Availability of Biomass and Wastes” by Barrier et al., Included in the ACS Symposium Book Series *Emerging Materials and Chemicals from Biomass*, cover–12 (Mar. 1991).

“Continuous Acid Hydrolysis of Cellulosic Biomass for Production of Xylose, Glucose and Furfural”, by Grethlein et al. *Food, Feed and Fuel from Biomass*, Chapter VIII, Part A1, 22 pages (undated).

“Continuous Acid Hydrolysis of Lignocelluloses for Production of Xylose, Glucose and Furfural” by Grethlein et al., *Food, Feed and Fuel*, Chapter 16, pp. 268–279 (undated).

“Glucose Decomposition at High Temperature, Mild Acid and Short Residence Times” by Smith et al., 22 pages (undated).

“Industrial Pyrolysis of Cellulosic Materials”, by Shafizadeh, *Applied Polymer Symposium*, No. 28, pp. 153–174 (1975).

“Kinetics of Acid Hydrolysis of Corn Stover” by McParland et al., 20 pages (undated).

“Kinetics of Dilute Acid Hydrolysis of Cellulose Originating from Municipal Solid Wastes” by Malester et al., *Ind. Eng. Chem. Res.* vol. 31, No. 8, pp. 1998–2003 (1992).

“Kinetics of the Acid Hydrolysis of Cellulose Found in Paper Refuse” by Eagan et al., *Environmental Science & Technology* vol. 5, No. 3 pages (1971).

“Potential Contribution of Furfural to the Economics of Ethanol Production from Hardwoods” by Barrier et al., Presented at the Southern Biomass Conference, Virginia Polytechnic Institute and State University, pp. cover–14 (Sep. 1989).

“Thermal Behavior of Carbohydrates” by Shafizadeh, *J. Polymer Sci: Part C* No. 36, pp. 21–51 (1971).

“Wastepaper as a Feedstock for Ethanol Production” by Bergeron et al., National Renewable Energy Laboratory, 28 pages (Nov. 1991).

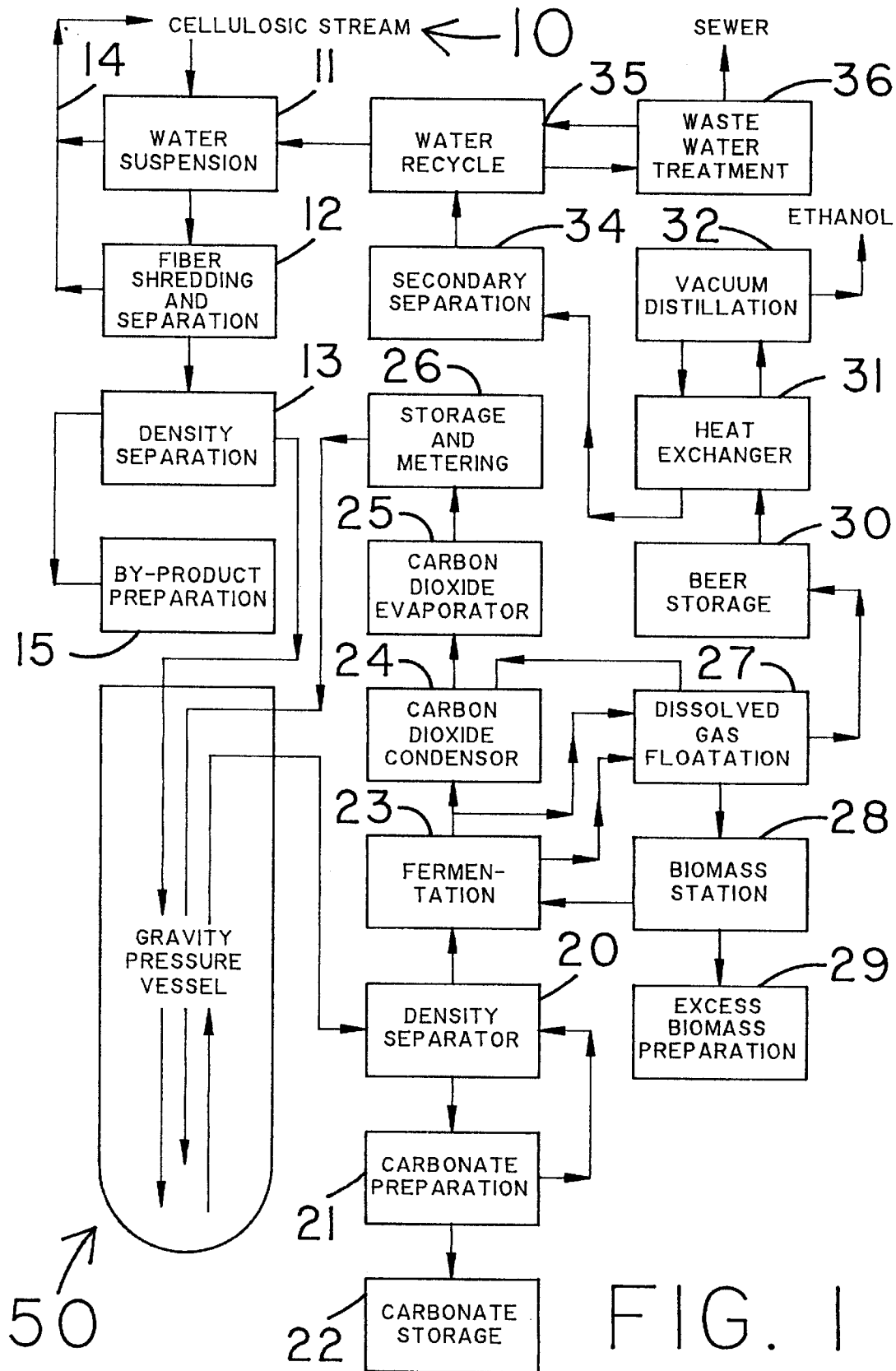
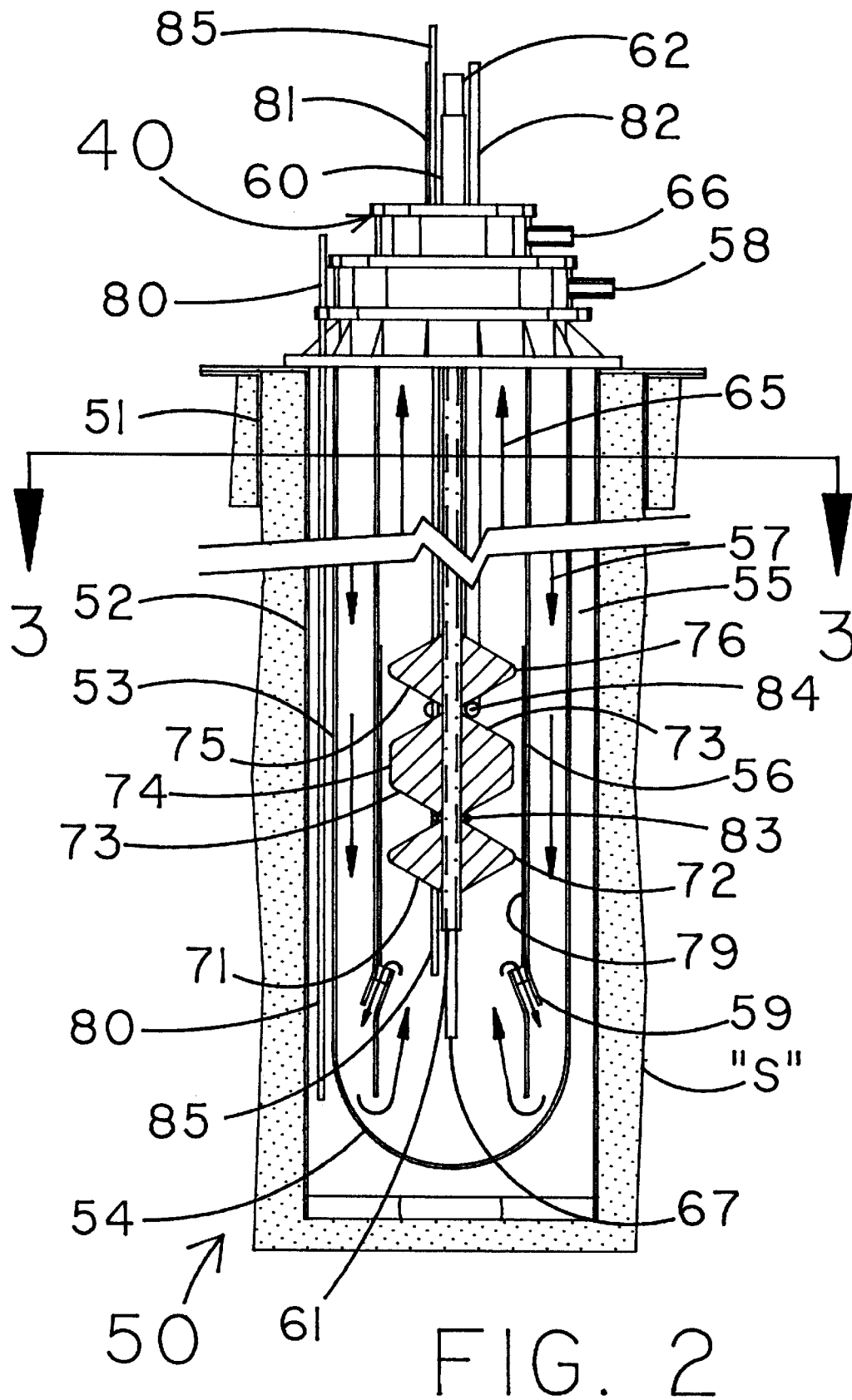

FIG. 1



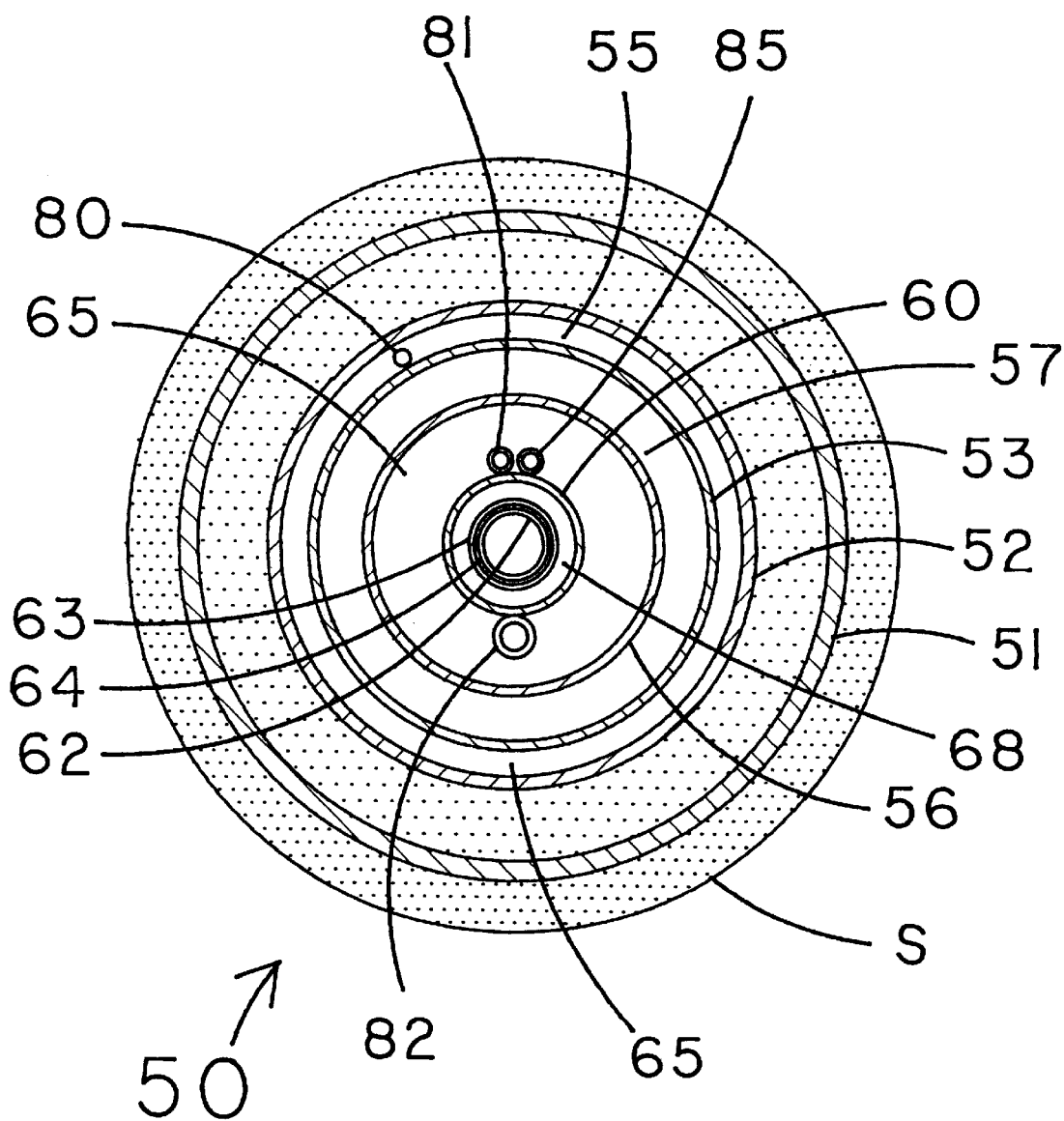

FIG. 3

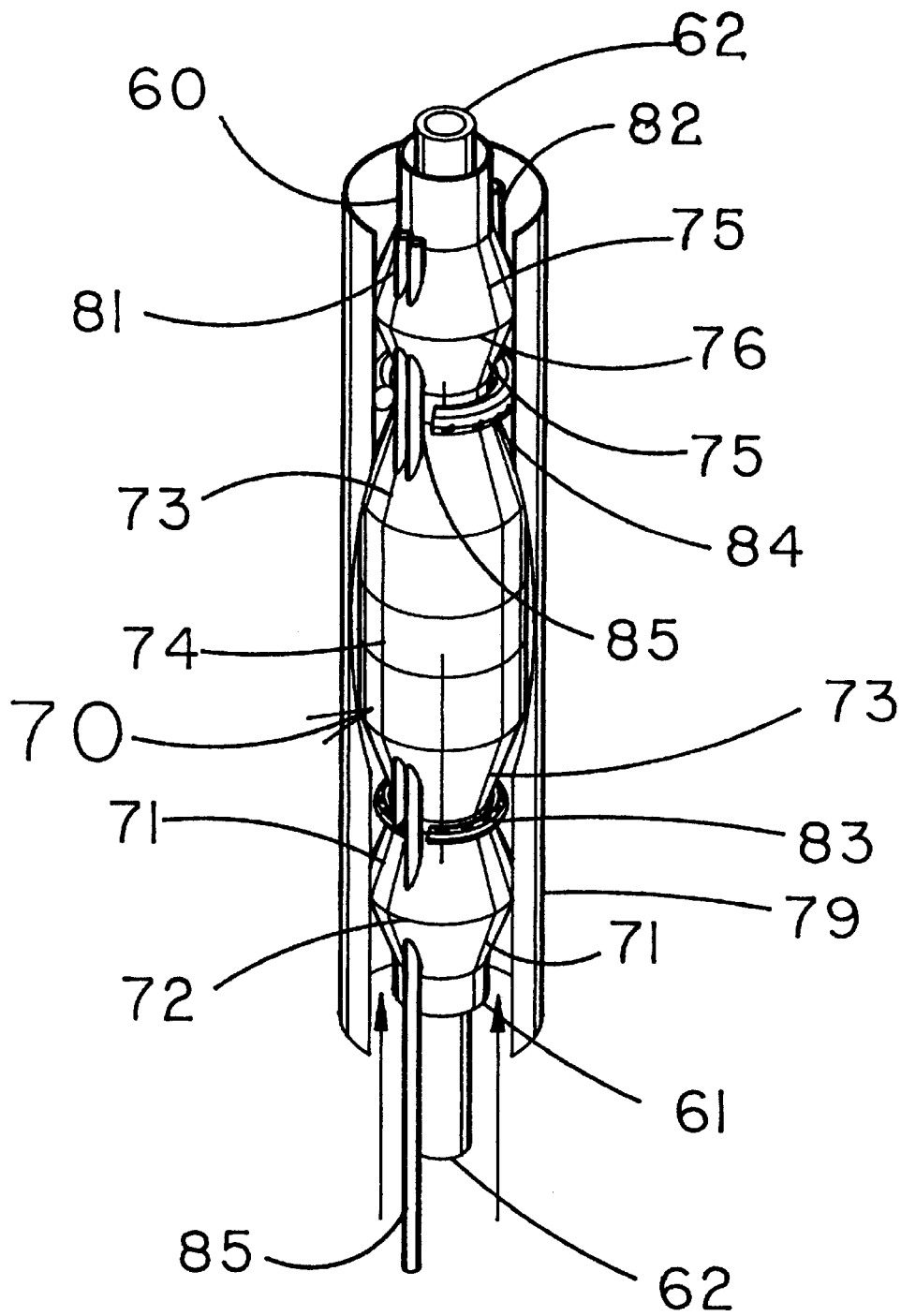

FIG. 4

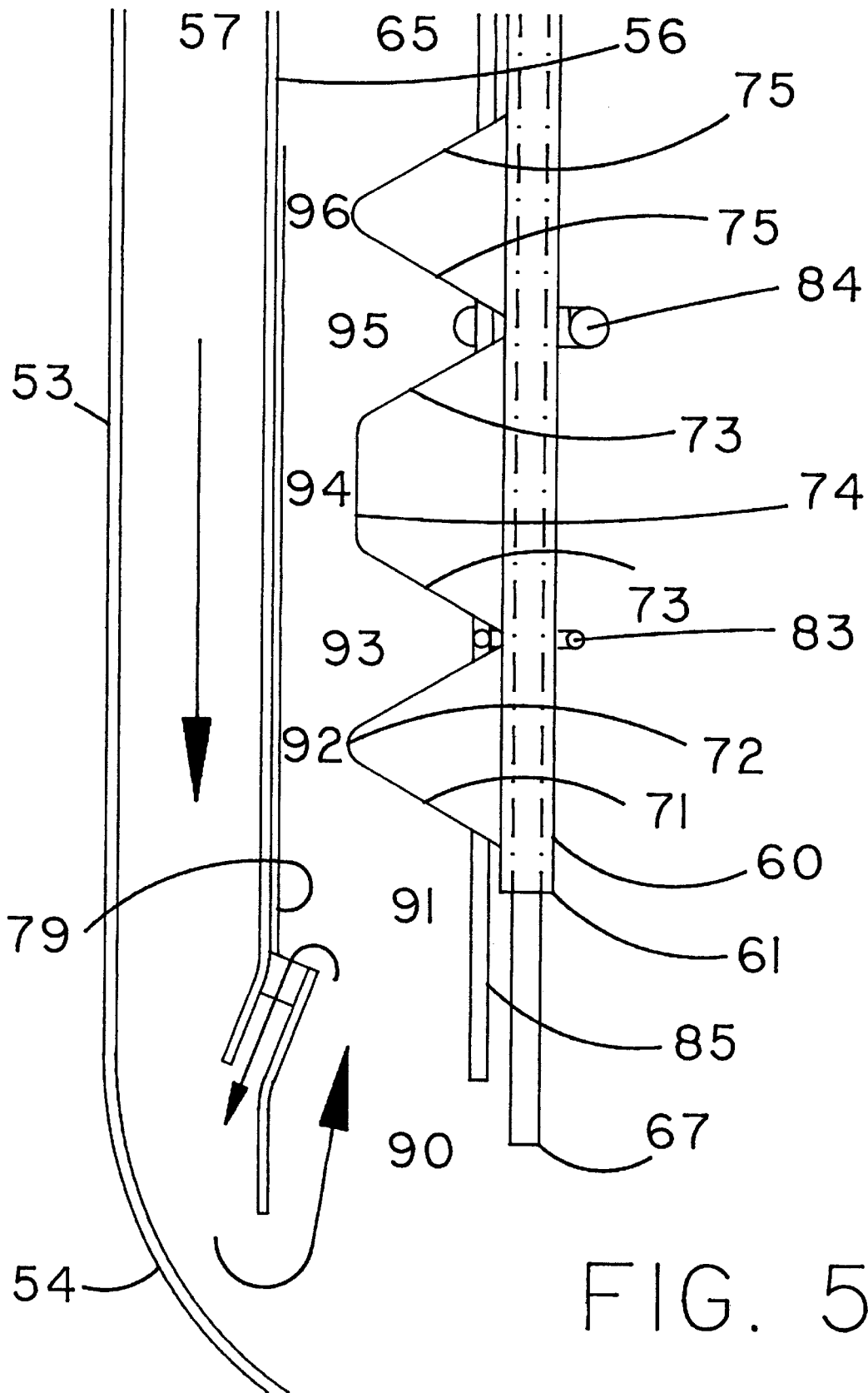

FIG. 5

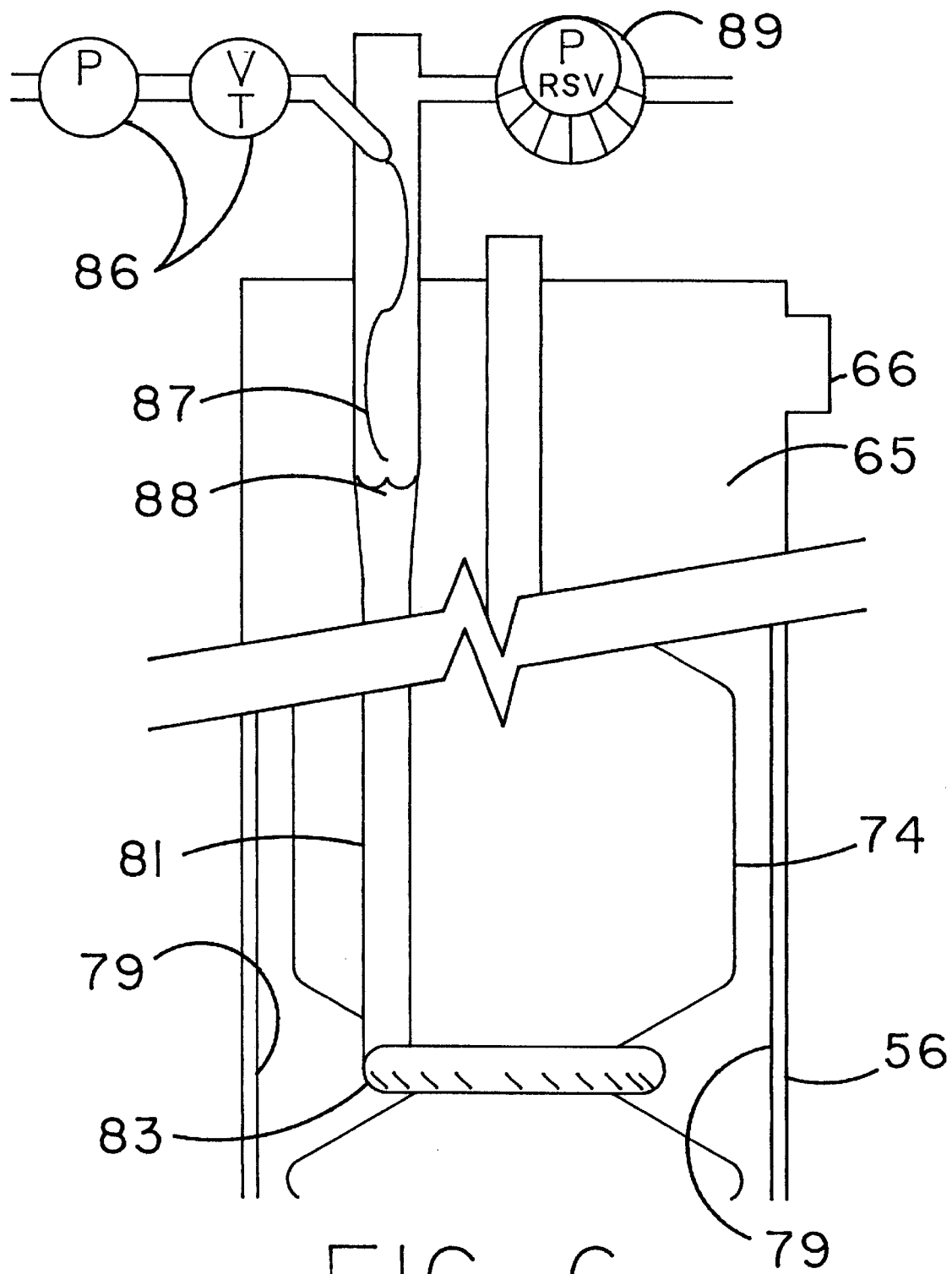

FIG. 6

APPARATUS FOR HYDROLYZING CELLULOSIC MATERIAL

This application is a division of application Ser. No. 08/644,401, filed May 1, 1996, now U.S. Pat. No. 5,711,817. 5

TECHNICAL FIELD

The present invention is generally directed toward a process whereby cellulosic material is converted to ethanol. Specifically, the present invention is directed toward an apparatus and method for the hydrolysis of cellulosic material to sugars which may be subsequently fermented. More specifically, the present invention is directed to an apparatus and method for the conversion of cellulosic material suspended in a fluid mixture via acid hydrolysis in a gravity pressure vessel. 10 15

BACKGROUND ART

Ethanol is a viable, economical, and relatively clean fuel substitute or additive. It is easily obtained from the fermentation of grain or other substances containing sugars and starches. Although grain and other sugar-bearing substances are in abundance, the conversion of cellulosic material, such as found in municipal solid waste, to sugar followed by the fermentation of the sugar has been found useful for the purpose of obtaining ethanol. The use of such waste cellulose has been particularly attractive in the face of higher grain costs and concerns about waste disposal. 20 25

Cellulosic material generally includes waste paper, agricultural chafe, municipal solid waste residual fluff, and wood products. These substances are converted to sugar via hydrolysis. Heretofore in the art, cellulosic material has been hydrolyzed by first reducing the material to a pulp and reacting that pulp with sulfuric acid. Upon the introduction of heat, hydrolysis begins and the cellulosic material is converted to sugar. The reaction is quenched by rapid cooling of the mixture, followed by acid neutralization. Rapid quenching is necessary because the hydrolysis reaction is virtually instantaneous, and over exposure to heat and acidic conditions will result in the decomposition of the sugar product thereby reducing yield. 30 35

This process, however, is thermally inefficient because the heat introduced to the system is lost through the rapid cooling of the system. Furthermore, inefficiencies resulting from the use of thick pulp solutions of cellulosic material, which conventionally contains approximately 20% suspended solids, have been recognized. Specifically, these solutions require screw augers to accomplish the required mixing of acid and heat. Thus, when a reaction vessel is 1,000 cubic feet, which is the minimum for commercial quantities, the time to achieve uniform mixing can be as long as twenty minutes. In addition to the inefficiencies associated with powering the auger, this process will result in poor sugar yields as the time required to uniformly mix the pulp is typically too long, resulting in the decomposition of the resulting sugar. 40 45

Although the problems associated with the use of thick pulps can be overcome by simple dilution with water, the added energy required to handle such liquid results in further inefficiencies. Indeed, the total energy required to produce ethanol via such a process is greater than the heat of combustion of the resulting ethanol. 50 55

Thus, a need exists to convert cellulosic material to sugar for the purpose of obtaining ethanol in an efficient manner. Specifically, to create an economical fuel substitute or additive, the thermal and chemical inefficiencies associated with the processes of hydrolysis described hereinabove must be overcome. 60 65

Numerous methods and reactions for carrying out hydrolysis are known in the art. For example, Titmas in U.S. Pat. Nos. 3,853,759 and 4,792,408 discloses a continuously flowing hydraulic column wherein materials suspended in water are heated and gravity pressurized to effect hydrolysis. The heated material is forced upward by column pressure and thereby cooled and depressurized. Although this process could handle large quantities of cellulosic material, poor net sugar yield would be obtained because there is no means to control or manipulate the length of the hydrolysis reaction, nor is there any means to abruptly and specifically control the quenching of the reaction. To achieve satisfactory sugar yields, the hydrolysis reaction must be stopped part way through the normal course of chemical events. This has not been accomplished heretofore in the art. 15

Also, Pavilon, U.S. Pat. No. 5,135,861, discloses a method of producing ethanol from an aqueous slurry of biomass. The carbon dioxide resulting from fermentation is captured and used to catalyze the hydrolysis of the biomass. Pavilon, however, fails to efficiently utilize the heat needed for hydrolysis to catalyze further hydrolysis reactions, and thus the energy needed to convert the biomass to ethanol is greater than the resulting heat of combustion of the ethanol. 20 25

Thus, there remains a need for a method and apparatus for the conversion of cellulosic material to ethanol. Specifically, there remains a need for a method an apparatus for the efficient hydrolysis of cellulosic materials which includes improving sugar yield and capturing the heat needed for hydrolysis to further additional hydrolysis which will in turn result in a process that is both cost effective and thermodynamically efficient. 30 35

DISCLOSURE OF THE INVENTION

It is therefore a primary object of the present invention to provide a method for the hydrolysis of cellulosic material to sugar. 35 40

It is a further object of the present invention to provide a method for the hydrolysis of cellulosic material, as above, that has improved chemical and thermal efficiency. 40 45

It is still a further object of the present invention to provide a method for the hydrolysis of cellulosic material, as above, that is continuous and capable of hydrolyzing large volumes of cellulosic materials. 45 50

It is a further object of the present invention to provide a method for the hydrolysis of cellulosic material, as above, whereby a significant portion of the fluid temperature is internally recovered. 50 55

It is another object of the present invention to provide an apparatus for the hydrolysis of cellulosic materials. 55 60

It is yet another object of the present invention to provide an apparatus, as above, that efficiently recovers and utilizes the heat needed for hydrolysis to initiate further hydrolysis reactions. 60 65

It is still another object of the present invention to provide an apparatus, as above, that effectively provides for a predetermined reaction time and acidity level so as to maximize sugar yield. 65 70

At least one or more of the foregoing objects of the present invention together with the advantages thereof over existing methods and apparatus for hydrolyzing cellulosic materials, which shall become apparent from the specification which follows, are accomplished by the invention as hereinafter described and claimed. 70 75

In general, the present invention provides a method of hydrolyzing cellulosic material including the steps of pro-

cessing the cellulosic material into a liquid stream, feeding the liquid stream to the top of a hydraulic downdraft column, conducting the liquid stream from the bottom of the hydraulic downdraft column into a reaction area, heating the liquid stream and lowering the pH of the liquid stream within the reaction area, thereby hydrolyzing the cellulosic material to form sugar within the liquid stream, and conducting the liquid stream containing the sugar from the reaction chamber to the top of a hydraulic updraft column.

The present invention further provides a method of converting cellulosic material to ethanol including the steps of processing the cellulosic material into a liquid stream, reacting the liquid stream within a gravity pressure vessel thereby converting the cellulosic material to sugar, and fermenting the sugar thereby forming ethanol.

The present invention also provides an apparatus for hydrolyzing cellulosic material within a continuous liquid stream which includes a first vertical passageway for receiving the liquid stream near the top thereof. A reaction area communicates with the first vertical passageway for receiving the liquid stream near the bottom of the first vertical passageway. Means are provided for delivering a gaseous material to the liquid stream, and in addition, means are provided for delivering heat to the liquid stream. A second vertical passageway communicates with the reaction area and receiving the liquid stream near the bottom thereof and delivers the liquid stream near the top thereof.

A preferred exemplary apparatus and method for the continuous conversion of cellulosic material to ethanol, which incorporates the concepts of the present invention, is shown by way of example in the accompanying drawings without attempting to show all the various forms and modifications in which the invention might be embodied, the invention being measured by the appended claims and not by the details of the specification.

BRIEF DESCRIPTION OF THE DRAWINGS

FIG. 1 is a schematic diagram of the overall process and system for producing ethanol from cellulosic material.

FIG. 2 is a fragmented vertical, cross-sectional view of a gravity pressure vessel in place within the strata.

FIG. 3 is a sectional view taken substantially along line 3—3 of FIG. 2.

FIG. 4 is an isometric view of a portion of the gravity pressure vessel exposing the inner reactor casing.

FIG. 5 is an enlarged vertical, sectional view of the gravity pressure vessel particularly showing the reaction area.

FIG. 6 is a fragmented vertical sectional representation illustrating a device for inhibiting the excessive feed of a higher density fluid into the gravity pressure vessel.

PREFERRED EMBODIMENT FOR CARRYING OUT THE INVENTION

The overall process and system of the present invention is best described with reference to the schematic representation of FIG. 1. It should be understood, for purposes of this disclosure, particularly with regard to the schematic representation, that appropriate pumping devices and conduits are employed to move material between the various stages of the system. It should be further understood that the process which converts cellulosic material to ethanol is a continuous process, and therefore one of ordinary skill in the art will understand that various pumping devices and storage areas will be employed to maintain the process in continuous operation.

In one particular use, source material containing cellulosic material is typically obtained from municipal solid wastes, generally after the extraction of marketable goods. Source material, however, can be obtained from any of a number of sources, including but not limited to waste pulp from paper factories, spent cellulose from paper recycle plants, and refuse from food processing plants. The material obtained from municipal solid wastes is commonly referred to as residual fluff and generally includes paper scraps, lawn wastes, newsprint and cardboard, packaging wastes, wood, and food wastes which are usually rich in cellulosic content. Commonly, persons with such materials will pay for its removal.

Source material is delivered from source stream 10 to a water suspension tank 11 where water is introduced. With the introduction of water, some of the cellulosic material dissolves while some simply forms a suspension in the water, or an aqueous slurry. This mixture will be referred to hereinafter as the liquid stream. Within suspension tank 11, styrofoam and heavy materials are separated and returned to the source stream via 14.

From the water suspension tank 11, the liquid stream is delivered to a fiber shredding station 12 where solids are reduced to a common small size. When dealing with municipal solid wastes, it is specifically desirable to shred the solid underwater to preclude explosion of hazardous materials. This also allows a second opportunity to remove undesirable materials that were attached to the cellulosic material in the liquid stream. The shredding station 12 may also be adapted to separate very dense materials, such as steel bottle caps, as well as light materials such as a styrofoam. These undesirable materials are also returned to the source stream via 14.

The liquid stream is then received by a density separator 13, such as a clarifier, where gravity separation allows for the separation of supernatant materials lighter than water. Such supernatant materials typically include polyethylene plastics, styrofoam and the like, which are floated to the top and removed for further processing which can include pelletization such as at by-product preparation stage 15. Heavier subnatent materials, mostly cellulosic material, remain in the liquid stream. For purposes of this disclosure, the steps described above will generally be referred to as processing the cellulosic material into a liquid stream.

The processed liquid stream is then introduced to a gravity pressure vessel 50 for hydrolyzing cellulosic material. For example, when municipal solid wastes are employed, the liquid stream delivered from the shredding station 12 typically includes about five percent solids, and following density separation at 13 the liquid stream is concentrated to about nine percent or more suspended solids.

Within the gravity pressure vessel 50, which will hereinafter be described in more detail, the liquid stream is subjected to proper conditions for carrying out acid hydrolysis. This hydrolysis converts a significant portion of the cellulosic materials to sugars. It should be appreciated that the resulting sugars become part of the liquid stream following hydrolysis. For purposes of this description, the term sugars will generally refer to those products resulting from the acid hydrolysis of cellulosic materials, typically definable as sugars and starches and derivatives thereof. It should be appreciated, however, that a very broad spectrum of resultant materials may result from hydrolysis, even when closely controlled feed stocks are employed. Thus, when viewed in light of the fact that a source stream of the present invention could include more than 10,000 identifiable

5

materials, many forms of sugars or starches are possible. When converting municipal solids wastes, the acid hydrolysis will yield a weak solution containing approximately 3.5 percent to approximately 5 percent sugar, which will produce a weak beer in fermentation.

The liquid stream, now containing an aqueous sugar solution, is delivered to a post treatment clarifier, such as density separator **20**. Within this clarifier, heavy refractory cellulose, lime, gypsum and inert precipitates are removed. These materials are forwarded to a dewatering or carbonate preparation process **21** where the water, which contains sugar, is removed and returned to the liquid stream at separator **20**. The solids, which can generally be defined as carbonates with some sulfates and mud, are stored at carbonate storage **22** for future commercial use.

The aqueous sugar solution, which also contains residual particles of unreacted cellulose, is delivered from separator **20** to a fermentation apparatus **23**, which typically includes several tanks. Not shown are certain heat exchangers that may be necessary to precondition the aqueous sugar stream. This preconditioning generally includes extracting furfural and other fermentation inhibitors known to those skilled in the art. Fermentation at apparatus **23** generally involves the introduction of conventional beer yeasts, and the maintenance of active moderate agitation, atmospheric pressure, and a temperature in the range of about 70° F. to about 100° F. Maximum sugar yield typically occurs within the time duration of about 24 to about 36 hours, with variations in time, as well as temperature, depending on the selection of yeast and other stimulating additives such as enzymes.

The products of fermentation are ethanol and carbon dioxide, produced in 1:1 ratio as generally understood by those skilled in the art. The carbon dioxide is captured from fermentation apparatus **23** and directed to a cleaning station **24**, such as a condenser. Here, the carbon dioxide can be condensed under pressure and cooled for purification. The purified liquid carbon dioxide is delivered to an evaporator **25** and stored at a metering station **26** for future use in the hydrolysis of the cellulosic material at gravity pressure vessel **50**, or elsewhere in the process as needed. Generally, when municipal solid wastes are employed as source material, about 80 percent of the acidification needs for hydrolysis are satisfied using carbon dioxide produced during fermentation.

Because the fermentation of the sugar took place in an aqueous solution, commonly referred to as beer, the resulting ethanol remains in aqueous solution. This beer is delivered to a dissolved gas floatation station **27**. Here, particulate impurities suspended in the solution are removed. These impurities include, but are not limited to, living organisms, dust, yeast and cellulose. Removal of such particulate impurities typically includes dissolving the carbon dioxide, or any gas such as air, in water under pressure. This solution is flash mixed with the beer in an atmospheric tank. As the dissolved carbon dioxide precipitates from the mixture, it attaches to nucleic bubble formation on the surface of the suspended solids. The combined bubble and suspended solid, now lighter than water, is floated to the surface.

The separated particles are conveyed to a biomass recycle station **28** where the yeast is tested and verified for seeding the fermentation process, and the remainder conveyed to an excess biomass preparation station **29** for conventional dewatering and shipment as a protein supplement for animal feed. The remaining liquid from the dewatering process is returned to the liquid stream.

The purified aqueous ethanol solution, or beer, is delivered to a beer storage station **30**. When distillation of the

6

ethanol is desired, the solution may be pre-heated by a heat exchanger **31** and then received by a vacuum distillation column or columns **32**. This can be any form of distillation and typically requires external heat from a source such as steam. After primary distillation at columns **32**, the distillate is transferred to a secondary separation apparatus **34** where residual organics are typically removed. Apparatus **34** could include, but is not limited to, engineered zeolite, reverse osmosis, or extraction and concentration using ice crystallization. It has been found that the use of evaporation to accomplish this secondary separation is far too mechanically and energy intensive to be economical or efficient.

The distillate is ethanol that is approximately about 95% to about 99% pure, or greater than 193 proof as commonly understood in the art. Further, the distillate can be dehydrated to achieve 199.5 proof. This distillate is cooled and delivered to either an awaiting transport vehicle or storage tank. The spent aqueous solution, on the other hand, is cooled and delivered to a recycle station **35**. It should be noted that the cooling of both the purified ethanol and the spent aqueous solution can occur within a heat exchanger, such as **31**, which is preferably a counterflow heat exchanger. Thus, heat from distillation process **32** is used to preheat the fluid stream of ethanol, i.e. beer, prior to distillation.

At recycle station **35**, the spent water is tested. Based on the quality of the water, the spent aqueous solution is recycled back to the system to suspend incoming cellulosic material at water suspension tank **11**, or treated at an on-site waste water treatment plant **36**. After treatment at **36**, the water may be diverted to a publicly owned treatment works or used at tank **11**. The treatment plant **36** should be capable of processing 72,000 gallons per day, with a net water discharge to the publicly owned treatment works preferably as low as 10,000 gallons per day.

On-site treatment plant **36** can include a conventional waste activated solids extended aeration biological waste water treatment plant wherein excess nitrates are removed prior to discharge to a publicly owned treatment works.

As previously described, the liquid stream of cellulosic material is hydrolyzed in gravity pressure vessel **50**. This apparatus is best described with reference to FIGS. 2 & 3. A tubular casing **52** is positioned in the strata S in a bore within the earth. Casing **52** can be separated from strata S with a grout to control the intermixing of fluids that may be present in the strata, to reduce the heat losses from the apparatus, and to protect the casing **52** from adverse corrosive effects of strata S. Optionally, a surface casing **51** may be employed, which is an additional tubular member encompassing strata casing **52** for the purpose of protecting water aquifers during drilling of the long string chamber bore hole.

Concentric within and spaced from casing **52** is an outer reactor tubular casing **53** having lower closed end **54**. The space between casings **52** and **53** forms an isolating annulus **55** that acts as a mutual barrier to protect the strata from the process and to protect the process from the strata. Such isolation may be enhanced by evacuating annulus **55** to a lower pressure, such as to approximately one thousandth of an atmosphere. Under such conditions, the integrity of casings **52** and **53** will be verified and heat loss to the strata from the apparatus will be greatly reduced, as will the corrosive effects on the surfaces of both casing **52** and outer reactor casing **53**. A closed and sealed drop tube **80** can be positioned in annulus **55** to house thermocouples to monitor temperature conditions within annulus **55**, as well as within the outer reactor casing **52**.

Concentric within and spaced from the outer reactor casing **53** is counterflow tubular casing **56**. The space

between outer reactor casing **52** and counterflow casing **56** forms outer reactor annulus **57**. The liquid stream containing cellulosic material, which enters the apparatus at inlet **58**, is caused to descend to a zone of higher pressure within outer reactor annulus **57**. This pressure results from the cumulative weight of the fluid, as well as from residual pressures from fluid handling pumps. Thus, annulus **57** essentially is a vertical passageway or hydraulic downdraft column that receives the liquid stream and delivers the stream to the bottom of gravity pressure vessel **50**. The bottom of counterflow casing **56** can be modified with an outward flare **59** to assist the induction of recirculation of the liquid stream near the bottom of annulus **57**, and produce a more uniform feed as the liquid moves through the reaction vessel.

As is best shown in FIG. 3, concentric within and spaced from the counterflow casing **56** is carbon dioxide input tube **60** which essentially is a means for delivering gaseous material to the bottom of vessel **50** via carbon dioxide annulus **68**. Carbon dioxide is delivered to the lower closed end **54** of reaction vessel **50** through input tube **60** from its discharge point at **61** as shown in FIG. 2.

Referring again to FIG. 3, concentric within and spaced from input tube **60** is a tubular steam pipe **62** which represents a means for delivering heat to the bottom of vessel **50**. Steam pipe **62** is concentrically nested within an outer tubular housing **63**, whereby steam pipe **62** and outer housing **63** form annulus **64** which may be insulated or evacuated to prevent the premature loss of heat from steam pipe **62**. Steam pipe **62** delivers heat energy, on an as needed basis, to the reactor vessel **50** from its discharge point at **67** to the region generally defined by the lower closed end **54** as shown in FIG. 2.

The space between carbon dioxide input tube **60** and counterflow casing **56** forms inner reactor annulus **65**, which defines a second vertical passageway or hydraulic updraft column. The liquid stream containing cellulosic material, which descends down outer annulus **57**, subsequently ascends up inner annulus **65** and out of the reactor vessel **50** through outlet **66**. The forces driving this ascension, as well as the reactions taking place to the cellulosic material as it ascends, will be described in greater detail hereinafter.

As is best depicted in FIG. 2, the gravity pressure vessel is capped with device **40**. Generally device **40** will serve to seal the annuli of reactor vessel **50** from the atmosphere, thereby maintaining the desired pressure or vacuum. As is generally shown, device **40** can be equipped with the inlet **58** and the outlet **66** previously described, although those of ordinary skill in the art will be able to modify the device **40**, based on the teachings herein. Of course, device **40** is able to accommodate various feed pipes and housings for analytical devices, which will both be described hereinafter and which one of ordinary skill may find necessary to achieve the objects of this invention based on the teachings herein.

To a portion of the vertical length of carbon dioxide input tube **60** there is removably attached an inner reactor casing generally indicated by the numeral **70**. More specifically, inner reactor casing **70** is removably attached to and circumscribes a portion of input tube **60**. It should be appreciated that, with inner reactor casing **70** attached to tube **60**, the shape of annulus **65** is modified. This modified area of annulus **65** essentially creates and defines a reaction area.

Inner reactor casing as generally indicated by the numeral **70** is best described with reference to FIG. 4. In the preferred embodiment, inner reactor casing **70** generally includes three venturi sections that are positioned along the same vertical axis with respect to the length of the carbon dioxide

input tube **60**. The first venturi section **71** generally includes two oppositely directed frustums connected at their bases, which circumscribe the carbon dioxide input tube **60**. As a result of this configuration, the inner annulus **65** is reduced at the junction of the two bases **72**.

The second venturi section **73**, which is positioned above and connected to the first venturi section **71**, generally includes two oppositely directed frustums having a generally cylindrically shaped member **74** connected therebetween. Cylindrical member **74** preferably has the same diameter as the bases of the frustums, and the bases of each frustum are connected to member **74**. The frustums and the cylindrical member circumscribe the carbon dioxide input tube **60**. As a result of this configuration, the inner annulus **65** is reduced at the junction of the bases and cylindrical member, and remains reduced throughout the vertical length of member **74**. As is particularly the case with member **74**, the length and configuration of the inner reactor casing **70** can be modified. For example, reactor casing **70** can be removed and member **74** can be modified in length. This is typically accomplished by replacing it with a longer member or by simply adding additional members, similar to **74**, between the frustums of the second venturi section. In turn, lengthening member **74** will increase the length of the reduced portion of annulus **65**.

The third venturi section **75**, which is positioned above and connected to the second venturi section **73**, generally includes two oppositely directed frustums connected at their bases **76**. The frustums circumscribe the carbon dioxide input tube **60**. As a result of this configuration, the inner annulus **65** is reduced at the junction of the two bases **76**.

It should be understood that while the inner reactor casing has been described with reference to the preferred embodiment, the inner reactor casing can be any means that serves to reduce and expand the width of inner annulus **65** in a manner generally consistent with that described in the preferred embodiment. Specifically, based on the teachings herein, one skilled in the art should be able to design numerous configurations that serve to alter the flow rate of fluid as it travels up annulus **65**.

Also represented in FIG. 4 are an acid feed pipe **81** and a caustic feed pipe **82**. In the preferred embodiment, acid feed pipe **81** supplies acid to an acid feed collar **83**, which is generally positioned at the junction of first and second venturi sections. From acid feed collar **83**, acid can be dispersed throughout inner annulus **65** in the region generally adjacent to feed collar **83**. Caustic feed pipe **82** supplies caustic to a caustic feed collar **84**, which is generally positioned at the junction of second and third venturi sections. From caustic feed collar **84**, caustic solution can be dispersed throughout inner annulus **65** in the region generally adjacent to feed collar **84**. It should be understood that any means of delivering acid and caustic to the above defined regions can be employed for purposes of this invention. Further shown in FIG. 4 is thermocouple tubular housing **85**, which may be employed to monitor the physical and chemical characteristics of the continuously flowing fluids within reactor vessel **50**.

The apparatus as just described is highly useful to perform the process of converting cellulosic material to sugars for the subsequent conversion to ethanol. As previously described, the term sugars is generally meant to refer to those products resulting from the acid hydrolysis of cellulosic materials. This conversion occurs via chemical reactions taking place within vessel **50** as cellulosic material, dissolved or mixed within an aqueous stream, continuously flows through the vessel.

The hydrolysis of cellulosic material is now best described with reference to FIG. 5. Steam, which is pumped down steam pipe 62, is introduced to the process and heats the stream of fluid in the region 90, generally defined as that region near the lower closed end 54 of reactor casing 53. Moreover, once the vessel is in continuous operation, heat resulting from acid hydrolysis reactions taking place in reaction regions 92 and 93, as will later be explained, migrates through counterflow casing 56 to heat the fluid stream as it descends down outer reactor annulus 57. Thus, steam from pipe 62 is delivered only on an as needed basis; that is, to compensate for that portion of downflowing fluids insufficiently preheated through counterflow 56. It is noteworthy that a maximum amount of heat energy can be recaptured by introducing the steam in the region 90.

It should be appreciated that the heat needed to drive a hydrolysis reaction of cellulosic material is generally greater than 200° C. and preferably in the range between about 260° C. and about 290° C. The greater the temperature, the less acid is needed to drive the reaction. At too great a temperature, however, the hydrolysis reaction is not easily controlled, and, therefore, results in the decomposition of the sugar product. Thus, based on the teachings herein, one of ordinary skill in the art will be able to alter the temperature and acidity level to achieve optional results. Of course, the constantly changing feed stream will also factor into the optimal temperature and acidity sought. It should further be appreciated that the pressure experienced by the liquid stream within the gravity pressure vessel increases as the liquid stream approaches the bottom of the vessel. This increased pressure, which is generally in the range of between about 600 psi and about 1200 psi, and preferably between about 800 psi and about 1000 psi, further serves to drive the hydrolysis reaction.

Because of the pressure resulting from the height of the liquid stream descending down outer reactor annulus 57, and the reduction in the density of the fluid resulting from the introduction of carbon dioxide, the liquid stream is caused to ascend up inner reactor annulus 65, a portion of which has been modified to define a reaction area as described hereinabove. For purposes of explaining the hydrolysis of the cellulosic material ascending up through the reaction area, the reaction area will be defined in terms of six regions. The first region 91 is generally defined as that region of annulus 65 below point 72 of first venturi section 71. At or near first reaction region 91 is the area where carbon dioxide input tube 60 terminates at 61, thereby introducing the carbon dioxide to the liquid stream in region 91. It should also be noted that the carbon dioxide is preheated prior to its entry in the process as a result of steam pipe 62 being concentric and within carbon dioxide input tube 60. The carbon dioxide forms carbonic acid within the liquid stream thereby lowering the pH and catalyzing the hydrolysis reaction. It is preferred that enough carbon dioxide be added to the liquid stream to bring the pH of the solution below 5.0 and preferably below 3.5.

The preheated liquid stream, now containing sufficient carbon dioxide, continues to ascend up annulus 65 and encounters the second reaction region 92 where the flow of the fluid stream is restricted due to first venturi section 71. The liquid stream's contact with venturi section 71 creates a minor shock wave in the passing fluid that is a source of instantaneous mixing of the fluid and suspended particles.

Moving upward through annulus 65, the fluid stream next enters third reaction region 93. Region 93 is generally defined as the area within annulus 65 adjacent to or near the junction of first venturi section 71 and second venturi

section 73. Within region 93, acid is introduced to the system from a device such as acid feed collar 83, to achieve a pH in the range of about 2.0 to about 3.0, which carries out hydrolysis of the cellulosic materials. While it is believed that any mineral acid will serve to lower the pH as sought in the present invention, sulfuric acid has been found to work particularly well and is preferred. It is noteworthy that such acid is only needed when the pH is insufficiently lowered by the introduction of carbon dioxide to the liquid stream.

As acid hydrolysis reactions convert the cellulosic material to sugars, the fluid steam continues up annulus 65 and enters forth reaction region 94. Region 94 is generally defined as the area within annulus 65 adjacent to and reduced as a result of cylindrical member 74 of second venturi section 73. Region 94 is restricted to increase the flow rate of the fluid stream undergoing acid hydrolysis, thereby limiting the time in which hydrolysis takes place. As previously described, extended acid hydrolysis of the cellulosic material beyond the required time will destroy the sugars that are sought from the reaction. Typically, it will take about 2 to about 4 seconds for the fluid stream to ascend through region 94. Because the reaction time is critical and may vary on several factors including the nature of the feed stock, the length of region 94, and therefore the reaction time, can be changed. This is accomplished by adding or removing sections of tube 74 as was described hereinabove.

Moving rapidly through region 94, the fluid stream then ascends into the fifth reaction region 95. Region 95 is generally defined as the area within annulus 65 adjacent to or near the junction of second venturi section 73 and third venturi section 75. Within region 95, caustic solution, such as calcium hydroxide, is introduced via a device such as caustic feed collar 84. The introduction of caustic solution raises the pH to approximately 7.5 or greater, thereby quenching the acid hydrolysis reaction. The introduction of a neutralizing agent such as calcium hydroxide further results in the formation of precipitants such as calcium carbonate and calcium sulfate. To prevent the fouling of the annuli walls, seed powders of these precipitates can be added with the caustic solution to the stream, causing the formation of larger precipitate particles that can be later removed. It should be understood that any caustic solution can be introduced which will neutralize the stream of liquid, thereby quenching the hydrolysis reaction, so long as such caustic solution is not deleterious to the sugar product or liquid stream.

Ascending toward the top of reactor vessel 50, the fluid stream is again restricted in sixth reaction region 96 due to third venturi section 75 which creates shock wave mixing. Continuing to move upward from this region, the fluid ascends unrestricted up the remainder of annulus 65 and eventually reaches the top of the reactor vessel 50 where it exits the vessel at outlet 66.

As should be evident to one of ordinary skill in the art, the reaction time is a function of the rate of flow of the liquid stream through vessel 50. In other words, the reaction time is dictated by the time it takes the stream to move through the reaction area. Generally, the stream will pass through the reaction area within about 3 seconds to about 6 seconds.

It should be appreciated that the quenching of the hydrolysis reaction is achieved solely by the neutralization of the fluid stream. Thus, the heat introduced at the bottom of the reaction vessel at region 90 remains in the fluid or migrates through casing 56 and heats the downward flowing input stream. It should further be appreciated that as the fluid ascends unrestricted up the remainder of annulus 65 toward

the top and the reactor vessel **50**, at least 80 percent, and more preferably 90–95 percent of the heat introduced via the steam at or near region **90** is captured, i.e., migrates through casing **56**, or into one of the various feed pipes. In other words, the heat introduced to the reaction vessel is recycled within the gravity pressure vessel.

Also depicted in FIG. **5**, counterflow casing **56** can be fitted with a liner **79**. Although casing **56** has mechanical strength, liner **79** is relied on for resistance from chemical attack and erosional complications.

Referring again to FIG. **4**, it has been discovered that the introduction of acid through acid feed pipe **81** and feed collar **83** could be problematic because the density of the acid can be up to approximately 35 percent greater than the density of hot water and the acid feed pipe is typically about 2,000 feet long. If this weight is left to act only against the frictional forces within feed pipe **81**, the flow rate of the acid will exceed the required delivery rate of acid. Thus, because the accumulated pressure at the bottom of feed pipe **81** is excessive, irregularities in the discharge of the acid into the reaction region **93** could occur. To eliminate this potential problem, it is preferred to employ an arrangement, such as illustrated in FIG. **6**.

This arrangement will be referred to as a vacuum compensated feed. Generally, this arrangement includes acid feed pipe **81** modified with at least one taper **88**, such that the diameter of the acid feed pipe is smaller below the taper than above the taper.

The rate of acid feed is controlled by pump and valving **86**. The acid is admitted into acid feed pipe **81** in a downwardly tangential manner so as to form a falling film **87** that simply wets the inner surface of pipe **81**.

As the acid film **87** flows downward, it will eventually flood the entire inner diameter of feed pipe **81**, such as at taper **88**, and create a column of acid within pipe **81** below point **88**. In other words, the height of the column of acid is generally equivalent to the height of the acid feed pipe below the taper. A vacuum is drawn, using evacuation vane pump **89** on the area above the acid column not occupied by the downward flowing film **87**. Thus, the pressure at the bottom of feed pipe **81** is only the weight of the acid column, typically from taper **88** down to the feed collar **83**. It is, therefore, desirable to modify acid feed pipe **81** with taper **88** such that the length of acid feed pipe **81** below taper **88** will create a pressure at the bottom of acid feed pipe **81** equivalent or approximate to the pressure within annulus **65**, and more specifically, reaction region **93**. It should also be appreciated that the rate of acid feed can be used to manipulate the height of the acid column.

For example, when sulfuric acid is employed, about one pound per square inch for every 1.9 feet of height is achieved. Water, on the other hand, is about one pound per square inch for every 2.1 feet of height. These values were calculated after compensating for the loss of density due to fluid expansion that results from rising temperatures as the fluids move downward in the reaction vessel **50**. Based on a vessel 2000 feet deep, which is typical for mild acid hydrolysis reactions, the water pressure would be approximately 952.4 psi, while that of the acid would be approximately 1,052.6 psi. This difference causes acid delivery problems which are enhanced by the fact that the acid frictional forces are less than that of the water.

To alleviate this problem, taper **88** is created so that the distance between taper **88** and feed collar **83** is 1810 feet, thereby providing for a column of acid approximately 1810 feet. Thus, approximately 190 feet of the feed pipe is maintained under vacuum.

It should be appreciated that the height and diameters of each annulus within reactor vessel **50** are not critical, so long as the height and diameters are sufficient to achieve the goals of the present invention. Namely, the height must be such that sufficient pressure is achieved at the bottom of the reactor to drive an efficient hydrolysis reaction. Further, the height must be such that sufficient travel of the up-flowing fluid is achieved so that the heat needed for the hydrolysis reaction can be recycled into the down-flowing fluids through casing **56** in an efficient manner.

The diameter of the annuli is typically a function of the make-up of the feed stream as well as the reaction sought. Typically, the diameter of the entire vessel is greater when cellulosic material is converted to sugar than in other gravity pressure vessels. As discussed herein, however, the inner annulus **65** has a reduced diameter at certain points.

A preferred gravity pressure vessel according to the present invention will have a height from about 1800 feet to about 2200 feet. The diameter of outer reactor casing **53** is preferably about 24 inches to about 30 inches, and the diameter of counterflow tubular casing **56** is preferably about 18 inches to about 24 inches.

As with the size of the reactor, the fluid throughput of the reactor is a function of the characteristics of the feedstock. Ideally, the gravity pressure vessel of the present invention will process from about 500 to about 1000 gallons per hour of fluid stream, which typically comprises from about 5 percent to about 9 percent cellulosic material.

Further details of the pretreatment and post-treatment of the fluids and the treated products of the process and other materials of construction, proportions, cleaning, corrosion and erosion control, catalysts, alternative acids, vent extraction and control of volatile organic compounds, stress strain control, expansion compensation, and the like, would all be known to one normally skilled in the art and are not described herein.

It should thus be evident that the method and apparatus disclosed herein is capable of sustaining conditions amenable to the practical hydrolysis of cellulosic materials in commercial quantities, as the energy demands involved in pressurization and heating are significantly recovered from the process stream and not lost to mechanical forces. Further, the by-products of cellulose hydrolysis are fully contained providing options for their processing and environmentally safe use or control. As such, the objects of the present invention are fully accomplished. It is, therefore, to be understood that any variation evident falls within the scope of the claimed invention and, thus, the selection of specific component elements can be determined without departing from the spirit of the invention herein disclosed and described. For example, the size of the gravity pressure may be altered, as can the position and configuration of the reaction area. Thus, the scope of the invention shall include all modifications and variations that may fall within the scope of the claims.

I claim:

1. An apparatus for hydrolyzing cellulosic material within a continuous liquid stream comprising a first vertical passageway for receiving the liquid stream near the top thereof, a reaction area communicating with said first vertical passageway near the bottom thereof, means for delivering a gaseous material to the liquid stream, means for delivering heat to the liquid stream, means for delivering a mineral acid to said reaction area, means for delivering caustic solution to said reaction area, a second vertical passageway communicating with said reaction area for receiving the liquid stream

13

near the bottom thereof and delivering the liquid stream near the top thereof, and means for reducing and expanding the width of said second vertical passageway, thereby altering the flow rate of the liquid stream as it is delivered to the top of said second vertical passageway so as to be conducive to initiating and rapidly quenching a hydrolysis reaction. 5

2. An apparatus according to claim 1, wherein said means for delivering heat to the liquid stream delivers heat near the bottom of said first vertical passageway.

3. An apparatus according to claim 2, wherein said means for delivering heat delivers steam. 10

4. An apparatus according to claim 2, wherein said reaction area is a vertical passageway defined within the lower portion of said second vertical passageway.

5. An apparatus according to claim 1, wherein said means for delivering gaseous material to the liquid stream delivers gaseous material near the bottom of said reaction area. 15

6. An apparatus according to claim 5, wherein said means for delivering gaseous material delivers carbon dioxide.

7. An apparatus according to claim 1, wherein said means for delivering a mineral acid includes a pipe having at least one taper therein such that the diameter of said pipe is smaller below said taper than above said taper, whereby upon the downward tangential introduction of acid within said pipe there will be an acid column within said pipe generally equivalent in height to the height of said acid feed pipe below said taper. 25

8. A gravity pressure vessel for converting cellulosic material to sugar comprising:

a tubular casing;

an outer reactor tubular casing positioned within said tubular casing and having a lower closed end, whereby said tubular casing and said outer reactor tubular casing form an insulating annulus; 30

14

a counterflow tubular casing positioned within said outer reactor tubular casing, whereby said counterflow tubular casing and said outer reactor tubular casing form a first vertical passageway;

a carbon dioxide input tube positioned within said counterflow tubular casing, whereby said carbon dioxide input tube and said counterflow tubular casing form a second vertical passageway;

a tubular steam pipe positioned within said carbon dioxide input tube;

a plurality of venturi sections, each positioned along said carbon dioxide input tube and extending within the second vertical passageway, thereby selectively restricting the area within the second vertical passageway;

an acid feed pipe for delivering an acid to the second vertical passageway, said pipe including at least one taper; and

a caustic feed pipe for delivering a caustic material to the second vertical passageway.

9. A gravity pressure vessel according to claim 8 wherein said plurality of venturi sections includes first, second and third venturi sections.

10. A gravity pressure vessel according to claim 9 further comprising an acid feed collar positioned at the junction of said first and second venturi sections, said acid feed collar communicating with said acid feed pipe.

11. A gravity pressure vessel according to claim 9 further comprising a caustic feed collar positioned at the junction of said second and third venturi sections, said caustic feed collar communicating with said caustic feed pipe.

* * * * *